

ITEM	QTY	PART NUMBER	DESCRIPTION
1	1	TP9688A	
5	1	TP9818F-rev-B	
6	1	TP9688E	
7	1	TP9688J	
11	2	M4X20-STUD	
14	1	TP14467D	
17	2	TP6688U	
22	1	TP15122C	
23	1	TP9818D-rev-B	
24	1	M5X2-MINARB-SS	
27	4	TP15953J	
30	2	TP15953P	
31	2	M5X10-STUD	
32	1	TP15953Q	
33	1	TP15710	
34	1	TP15953N	
35	1	TP15953B	
36	2	TP15710D	
40	1	TP9688M	
42	1	TP15953L-RH	

REVISION HISTORY				
ZONE	REV	DESCRIPTION	DATE	APPROVED
B		SMALL CHANGES	2017-02-14	JS
C		1180mm WIDE DESIGN	2017-07-27	JS
D		12mm RECESS ON BASE BOTTOM	2017-10-23	JS

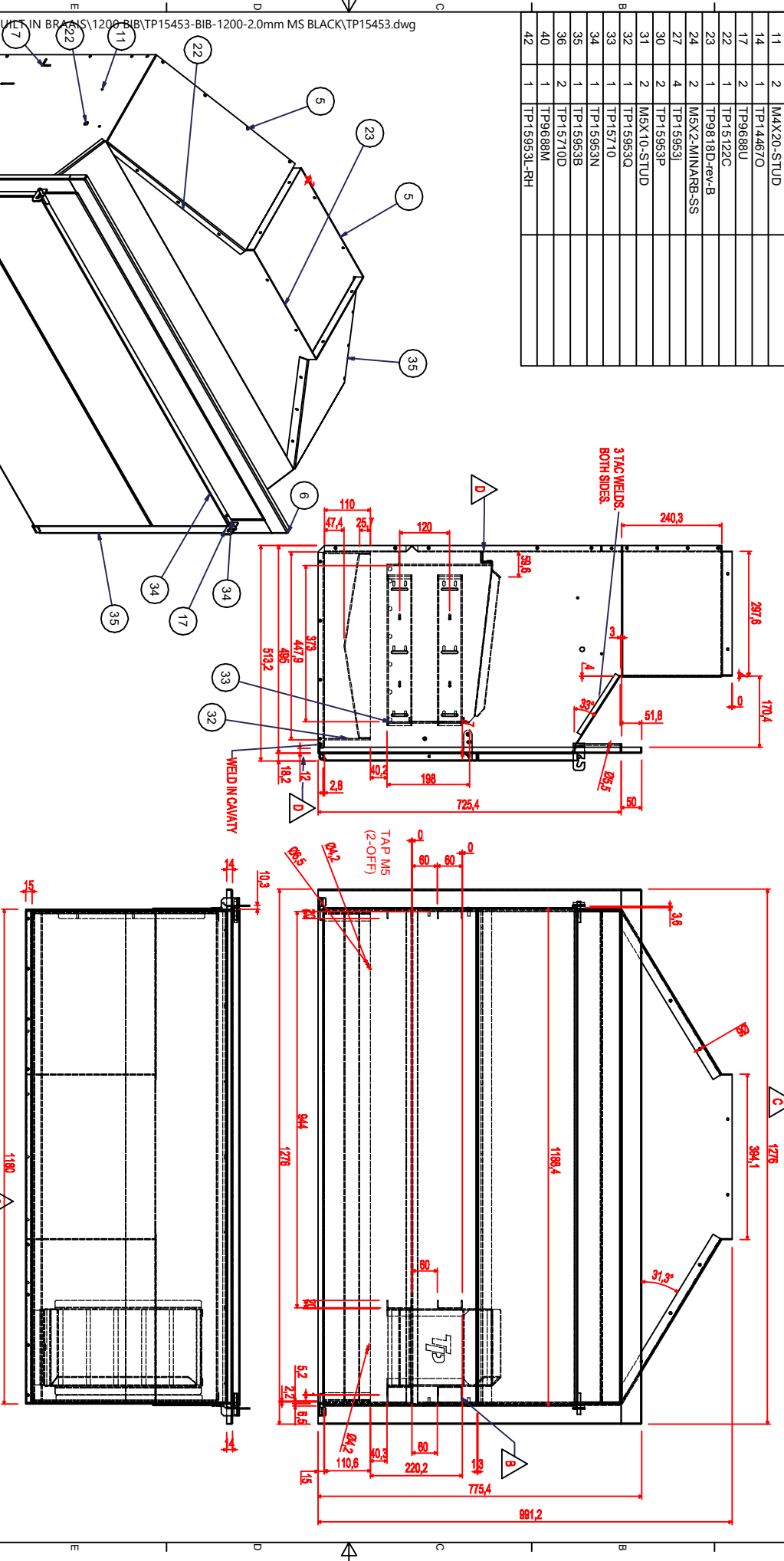

BIB-BUILT IN BRASS\1200 BIB\TP15453-BIB-1200-2.0mm MS BLACK\TP15453.dwg

BIB-BUILT IN BRASS\1200 BIB\TP15953-BIB-1200-430-SMALL\_BOX\_2.0mm\TP15953.dwg

CLIENT: TPP	REV: D	PROJECT: APPROVALS	DATE: 13/12/2016	TITLE: BIB 1180 - 2mm MS ECONO. 400X300 file.
REFERENCE: 15453	TOLERANCE: ±0.1mm	DRAWN: Johan Steyn	DATE: 13/12/2016	FINISH: BLACK
CLIENT/DWG: OPERATIONS:	±0.2mm	APPROVED:	DATE: 2016-12-12	MATERIAL: 2.0mm MS
1) PUNCH/LASER	1-BEND ±0.3mm	ORDER DATE: 2016-12-12	DATE: 2016-12-12	
2) DEBURR	BEND TO BEND ±0.3mm	SHEET: 1 OF 1	Dwg No: TP15453	QTY: 2
3) BEND	±0.05	SCALE:		
4) WELD	(BS 308 P173)			
5) CLEAN				
6) ?				